

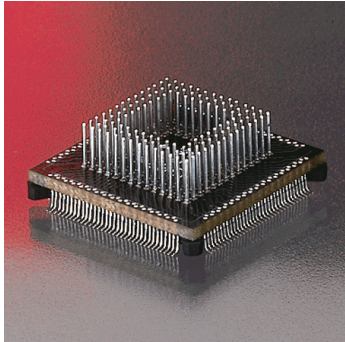

WINSLOW ADAPTICS

W98XXMTSOP TSOP SOLDER DOWN



This range of adapter enables the user to test and develop using the Winslow TSOP solder down range.

The assembly is designed to solder the TSOP solder down onto existing target lands and breaks out each signal to male pins on the top side. This enables easy interface to the adapter.

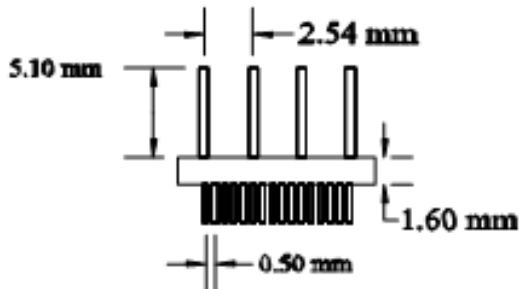
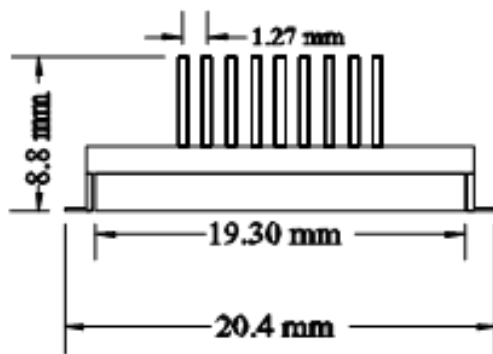
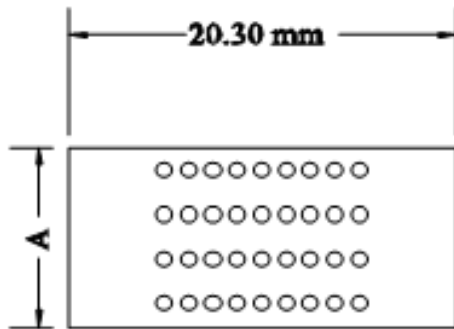

sales@winslowadaptics.com

DIP Support products from Winslow Adaptics

www.winslowadaptics.com



Custom Upgrades

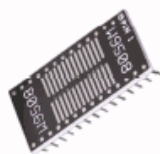

Package



Conversion

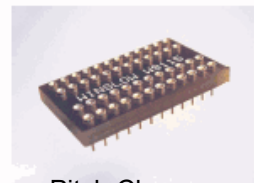
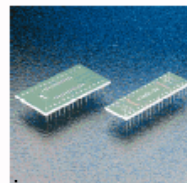

Pitch Change

Also available from Winslow Adaptics are cost effective, time saving solutions to test, obsolescence, supply problems and upgrades. OEMs can upgrade equipment with custom Adaptics utilising additional logic, often saving considerable cost and time on re-design. If lead-time becomes an issue contact us for a suitable package converter. We specialise in conversion of all package lead-frames.



W98XXMTSOP TSOP SOLDER DOWN

Part Number	Number of Pins	A
W9827M	28	8.5
W9828M	32	8.8
W9829M	48	12.9
W9830M	56	15.2
W9831M	40	10.8
W9832M	24	8.3

All dimensions in millimeters and are subject to change without prior notice.



Solutions to Component Leadtime and Obsolescence

Also available from Winslow Adaptics are cost effective, time saving solutions to test, obsolescence, supply problems and upgrades. OEMs can upgrade equipment with custom Adaptics utilising additional logic, often saving considerable cost and time on re-design. If lead-time becomes an issue contact us for a suitable package converter. We specialise in conversion of all package lead-frames. For further information please contact your nearest sales office

sales@winslowadaptics.com

www.winslowadaptics.com